

up-to-date electronics for lab and leisure

ELEKTOR

equa amplifier
quadro systems
tap sensor
steam whistle
distortion meter
mos clock

December 1974 35p



tap sensor

An important alternative to the mechanical switch — rotating or push-button — is the touch switch. This has the advantages of greater reliability and a higher switching speed, as well as being noise-

less and not subject to wear. Furthermore, front panels with touch contacts can be made available as printed circuits, so that it becomes much easier to build equipment with a neat appearance.

Elektor laboratories have been asked to design a touch control switch with a single touching point and costing no more than its mechanical equivalent. Consequently, our laboratories have produced the Touch Activated Programmer or TAP.

Basic possibilities

Operating a switch — touching, turning or pushing — is in effect feeding in a signal that must be stored somehow. The mechanical switches do this by remaining locked in their new positions; a touch switch, however, cannot store a signal

unless it is provided with a memory.

If a switch is to be operated by touch, its input resistance must exceed the resistance of the finger if action is to be ensured. If it is a single-point touch switch, the signal fed in — the signal that activates the switch — must be the noise or hum picked

up by the operator. Hence, the single-point touch switch consists essentially of an a.f. amplifier that has a high input impedance, a rectifier and a memory. This is shown in figure 3. In this system the input signal (hum voltage on the skin) is amplified in the input stage, rectified and fed

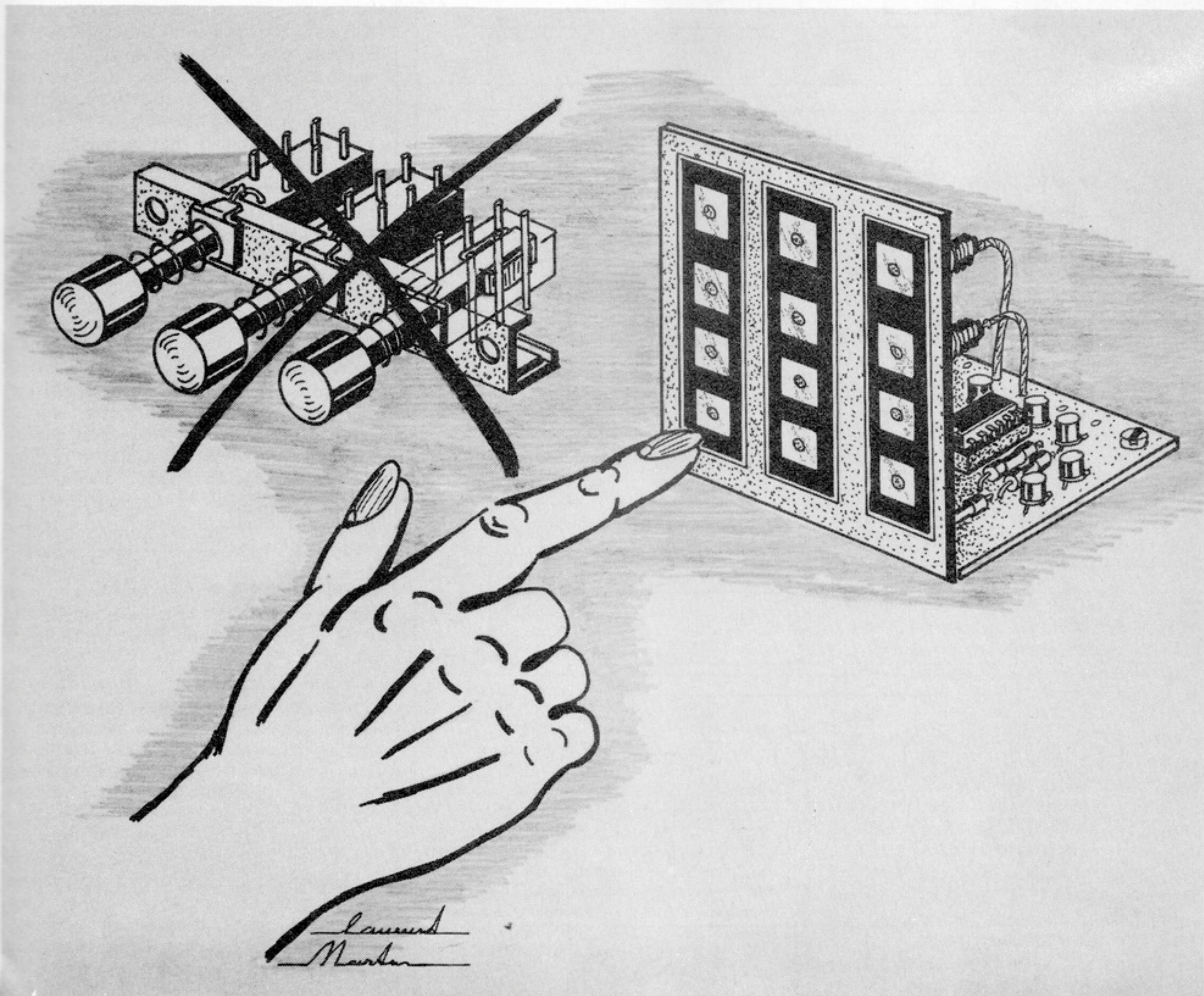

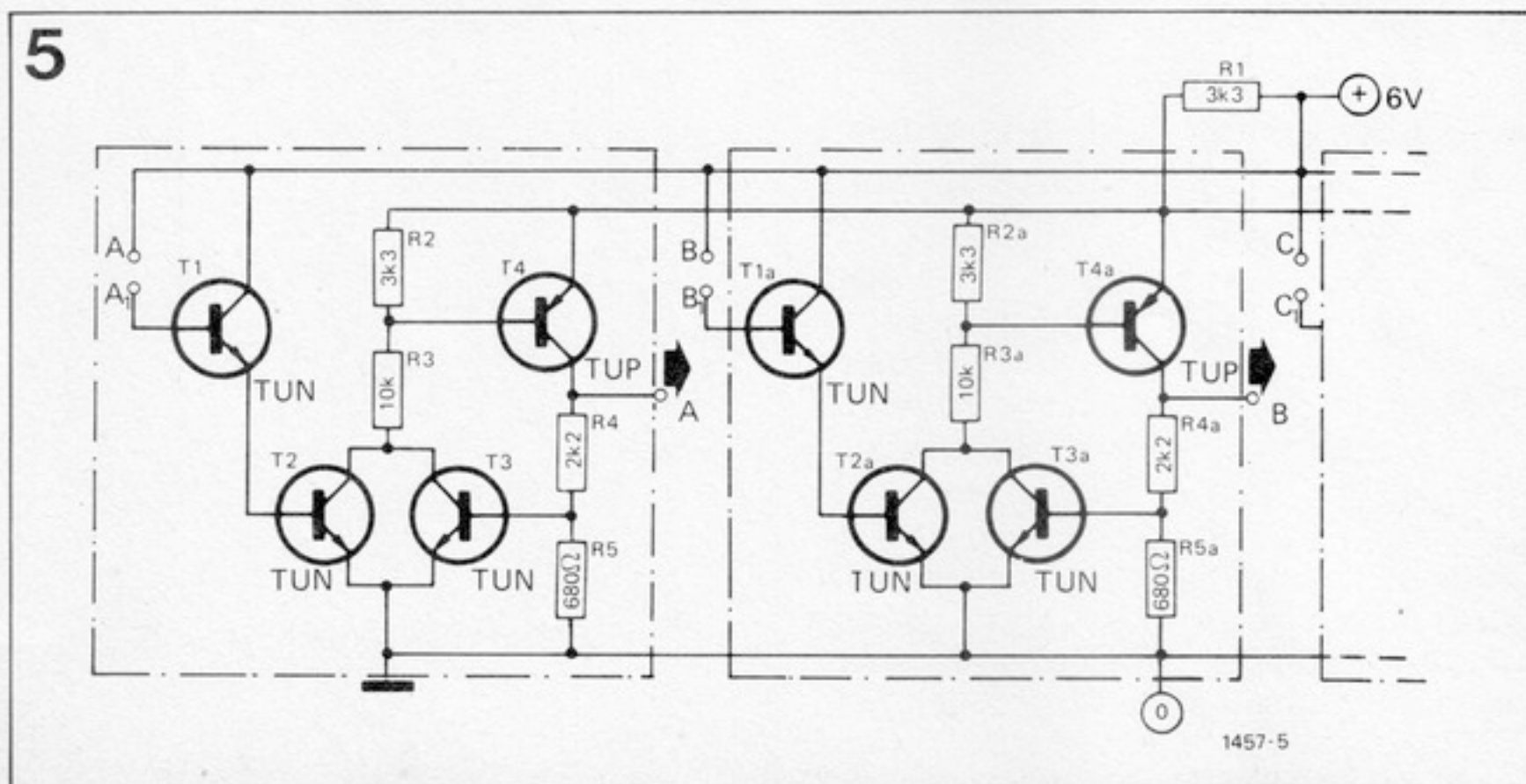
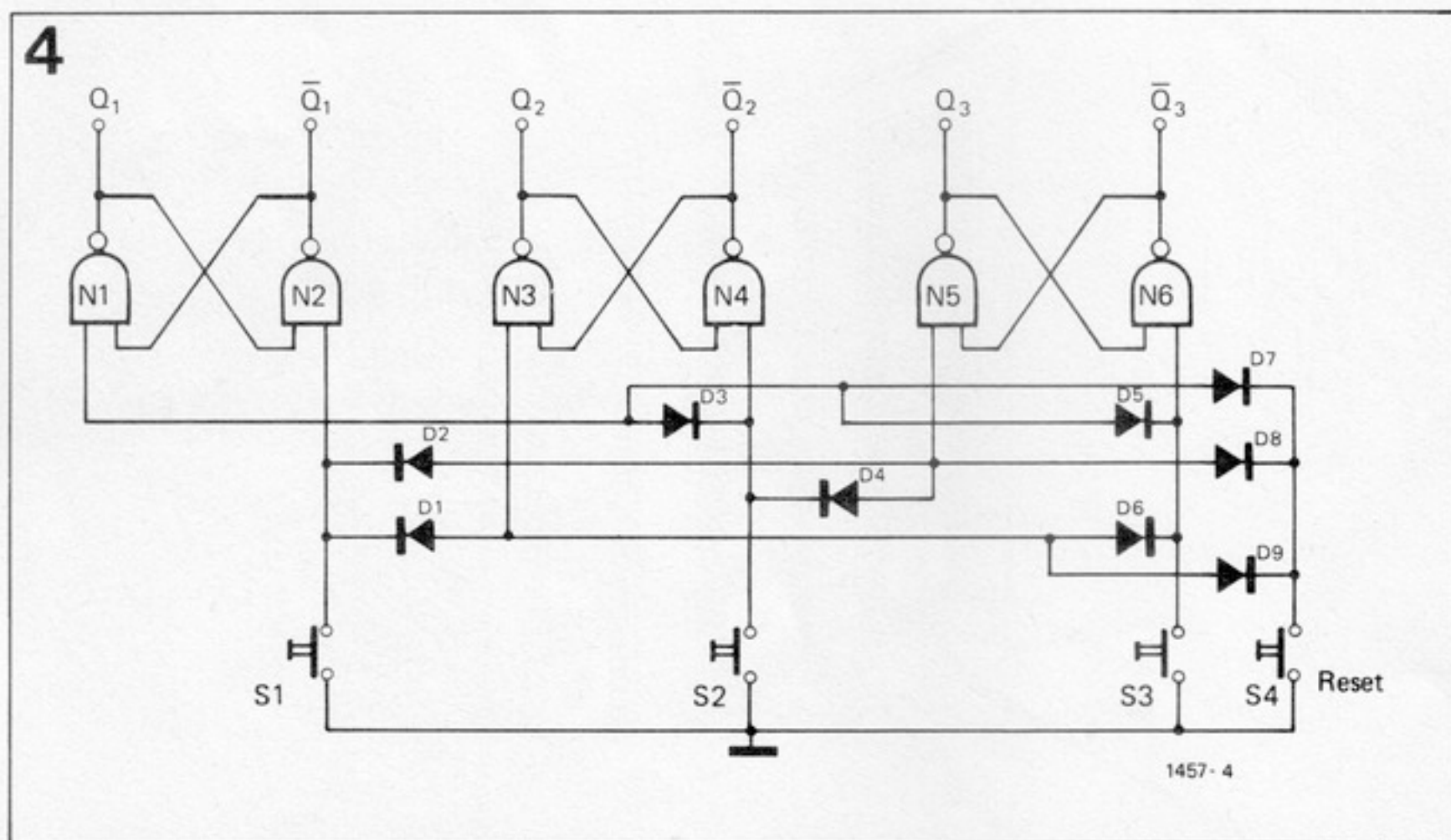
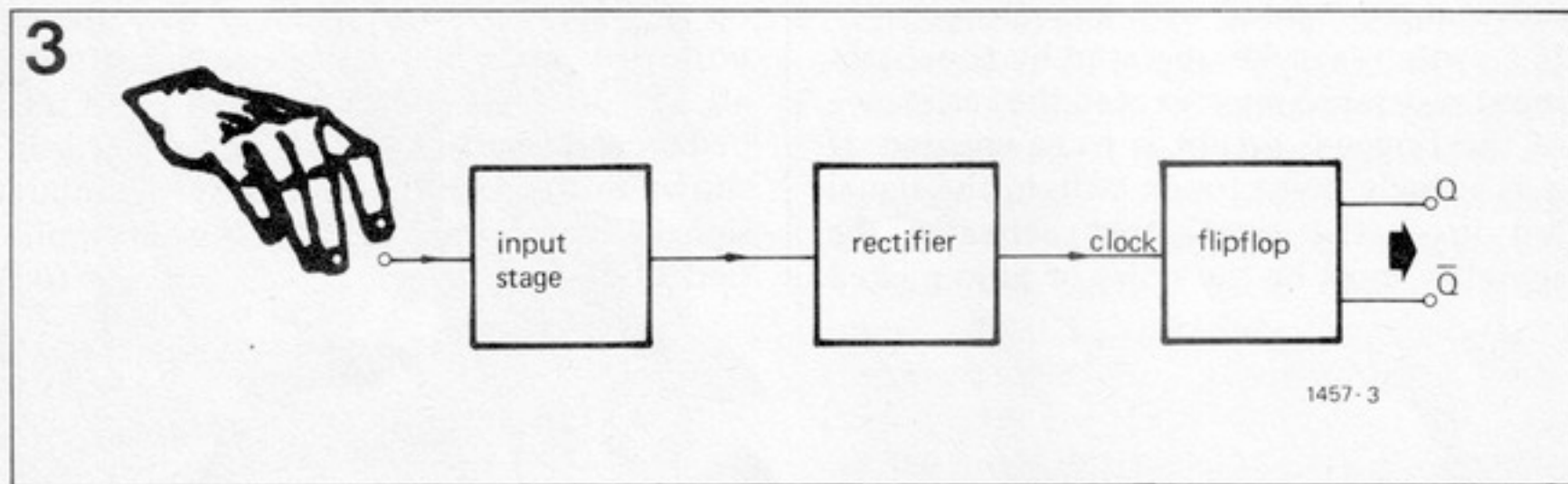
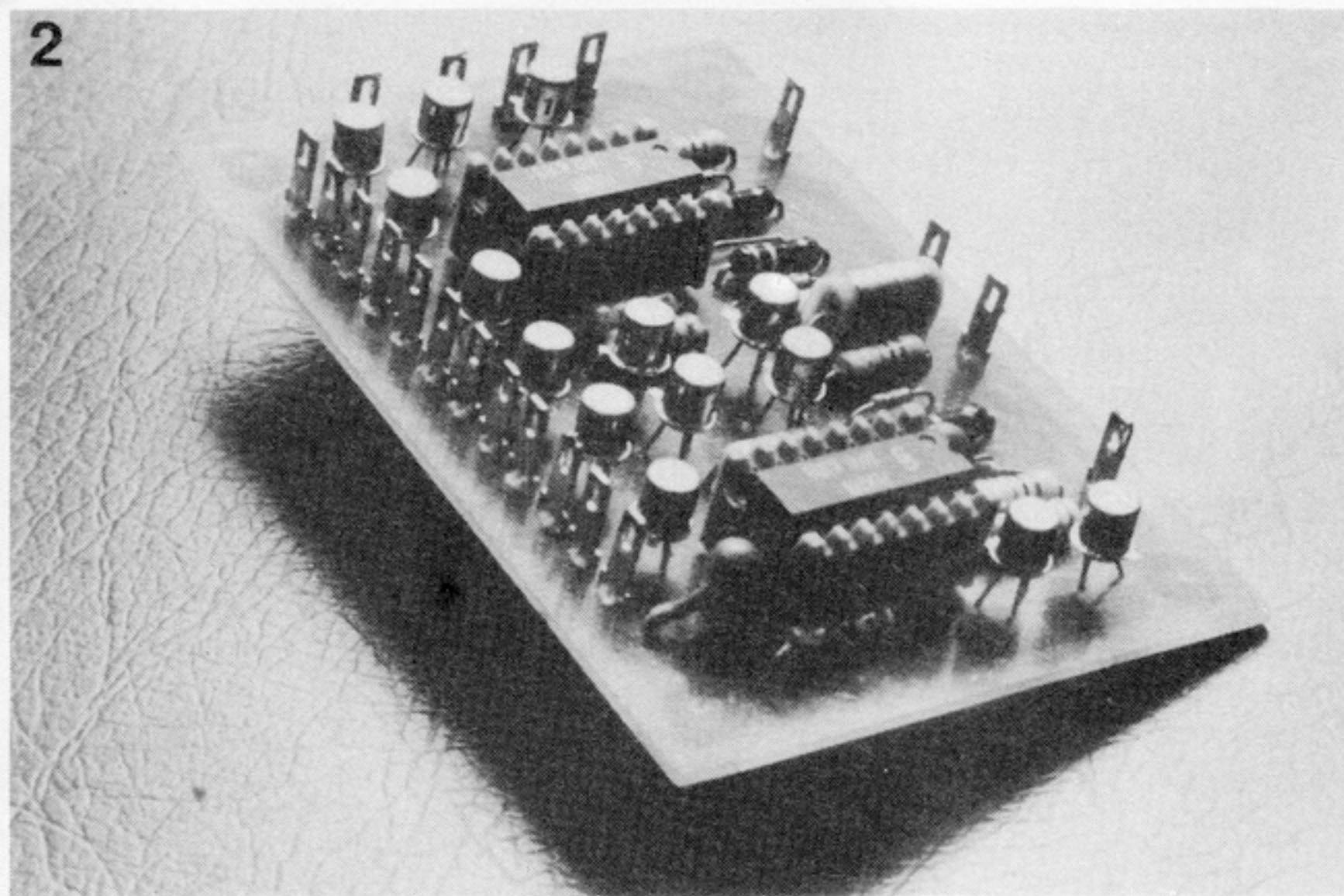

to the clock input of a flipflop. Each time the input point is touched, the flipflop will change to another stable position. A practical circuit in accordance with the block diagram of figure 3 is fairly simple to design.

A TAP (Touch Activated Programmer) that will replace a complete pushbutton unit needs a reset unit between the flipflops of the respective switches. This will ensure that when there are several switches, all except the one operated are reset. This reset can be achieved with diodes as shown in figure 4 with a four-position switch. For simplicity the contacts are shown as push-buttons. S_4 is the total reset button. The three-position switch shown in figure 4 needs nine diodes. In general, the reset circuit requires a number of diodes equal to the square of the number of positions. Hence, an eight-position switch (plus, of course, a total reset) requires 64 diodes. So the system of figure 4 is rather expensive, and the circuit becomes complicated when there are more than four positions. A touch control switch operating without reset diodes is shown in figure 5, points A/A₁ and B/B₁ being the touch contacts. Here reset is achieved by using a common supply resistor R_1 . If one of the switches is 'on', it draws a current of about 1mA. The voltage drop across R_1 is then 3.3V. As soon as the second switch is operated, this one, too, will want to draw 1mA. As a result, the voltage across R_1 drops almost to zero, the non-operated switch is cut off and the last switch to be operated remains 'on'. An advantage of such a switching system is that it can be easily expanded with more and more of the same units. There is the drawback, however, that extra components are needed to create 'hard' binary outputs. Consequently, the cost of the switch becomes so high that the financial requirements can no longer be met.

A better reset system uses a one-shot (monostable multivibrator). Each time a switch is touched, this one-shot circuit feeds a short reset pulse to each flipflop. This pulse must be so short that no audible interval occurs in low frequency applications of the switches. Laboratory experiments have shown that touch-control switches with this reset system provide the most reliable circuit. It is for that reason that they are used in the TAP.

Block diagram of the TAP

Figure 6 shows the block diagram of the TAP, points A, B and C being the touch points.

A separate overall reset is provided. Each touch point is followed by an input buffer circuit (IB-1, IB-2 . . .). These amplify the hum voltage on the skin. The input circuits of the touch points A, B and C drive the set-(S)-input of the RS flipflops. Since driving the set input of such a flipflop several times in succession will only lead to one change in its binary state, the rectifier circuit shown in figure 3 is not necessary here.

The input circuits also drive the one-shot. If, for instance, point A is touched, a 50 Hz square wave will appear on the S-input of the first flipflop (FF-1). At the

Figure 2. Photograph of the TAP.

Figure 3. Block diagram of a simple touch control switch with one input and two inverse digitale outputs.

Figure 4. A switching system with four digital (pulse) inputs and three binary outputs. The system is designed so that in all cases only one binary output assumes a set state whilst the other outputs are in the reset state or are being reset.

Figure 5. A touch control switching system where only one output at a time can be in the set state. This system can be expanded with an unlimited number of touch control switches.

Figure 6. Block diagram of the TAP. The letters FF, OS and IB stand for FlipFlop, One-Shot (= monostable multivibrator) and Input-Buffer.

same time the one-shot produces very short reset pulses. Because these reset pulses to the R-input are short as compared with the square wave at the S-input, the flipflop is not reset immediately after being set. A switch is reset only by operating one of the other two switches or the independent reset. As the block diagram of figure 6 shows, each TAP comprises three switching positions and one total reset. The circuit is designed so that several TAPs can be combined to a maximum of about 14 switching positions plus one total reset.

The RS-flipflop

In the TAP two NAND gates are coupled to form an RS-flipflop (see figure 7).

The S-input of the flipflop is driven from a transistor, that, in the active state, draws the input of the gate to supply zero. In figure 7 this is transistor T_6 , connected to input B, and driven by T_5 . If point D in figure 7 is touched, the hum voltage on the skin will drive T_5 into conduction; T_6 then goes into saturation and draws input B of the NAND gate to '0' 50 times per second. If D is not

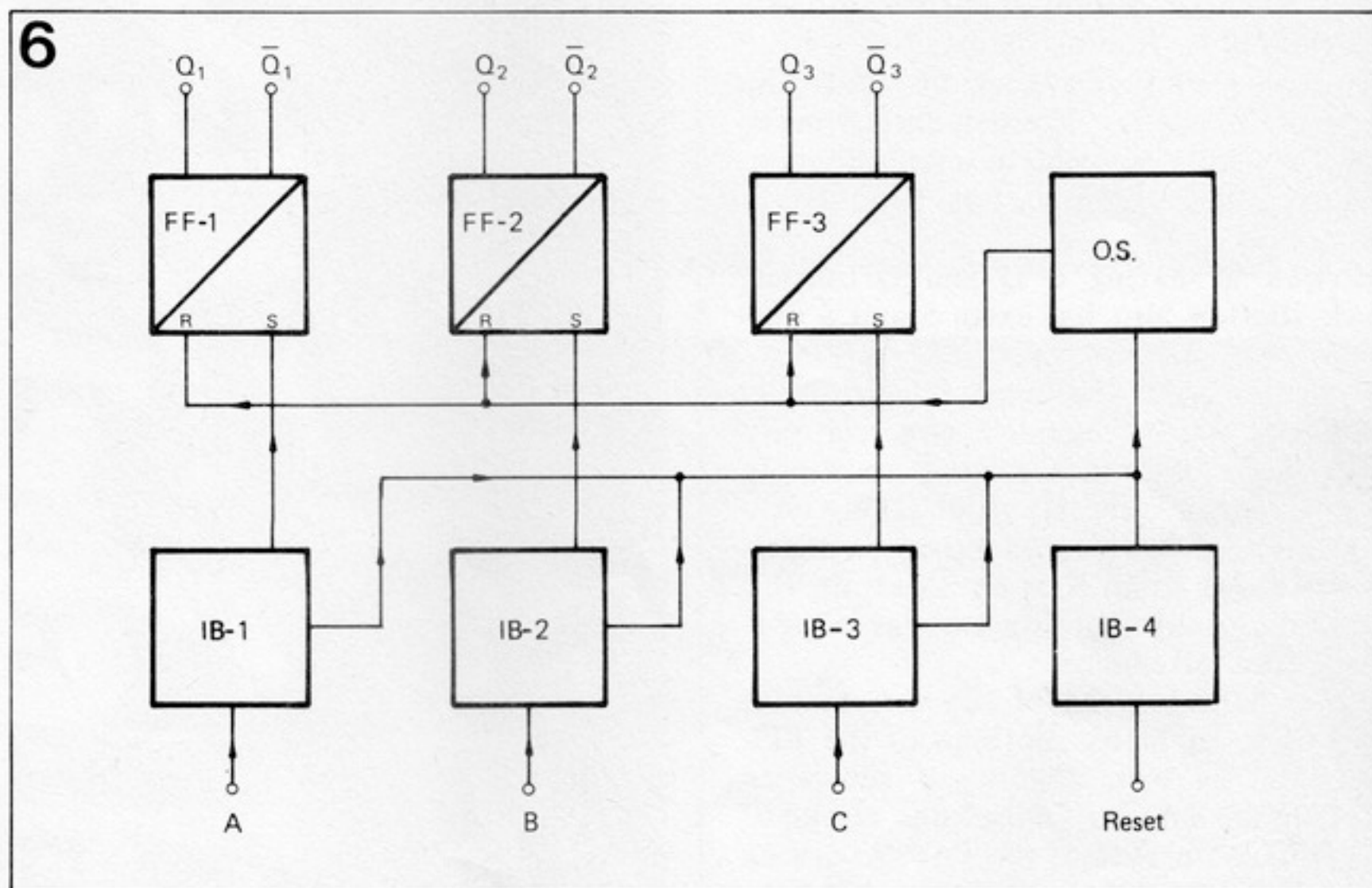

The 7400

The TAP is designed around the integrated circuit type 7400, a quadruple two-input NAND. Actually, the full type number will be SN 7400, S 7400, N 7400, SN 74H00, to name a few; the letters are not so important, however. To gain a good insight into the functioning of the TAP circuit, it is necessary first to take a closer look at this integrated circuit. The part surrounded by the dash-dot line in figure A represents the internal circuit of a NAND gate, and each 7400 comprises four such gates.

The two emitters of T_1 are the inputs of the NAND gate. When both emitters of T_1 receive a voltage $+V_B$, no current flows through its P-N base-emitter junction. The potential on the base of T_1 rises and the P-N base-collector junction conducts. Hence, here transistor T_1 can be regarded as an assembly of three diodes. The potential on the base of T_2 now rises and this transistor is turned on, so that its collector potential drops sharply. Consequently, T_3 no longer conducts and, at the same time, T_4 is driven into saturation. Point C, the NAND gate output, drops to zero potential (LOW). So when both inputs of T_1 are at $+V_B$ (HIGH), the output is LOW. It is also obvious that leaving the emitters of T_1 'open circuit' is in fact the same as applying $+V_B$.

As soon as one of the emitters of T_1 becomes LOW (logic '0'), the base voltage of T_1 will also drop. As a result, the base-collector junction of T_1 does not conduct, T_2 is no longer driven, and the output (C) will assume a HIGH level.

When the output of the NAND gate is HIGH (logic '1'), the output level is equal to the supply voltage $+V_B$ minus the drop in the diode D, the collector-emitter saturation voltage

Figure A. Circuit diagram of a NAND gate in a 7400 IC.

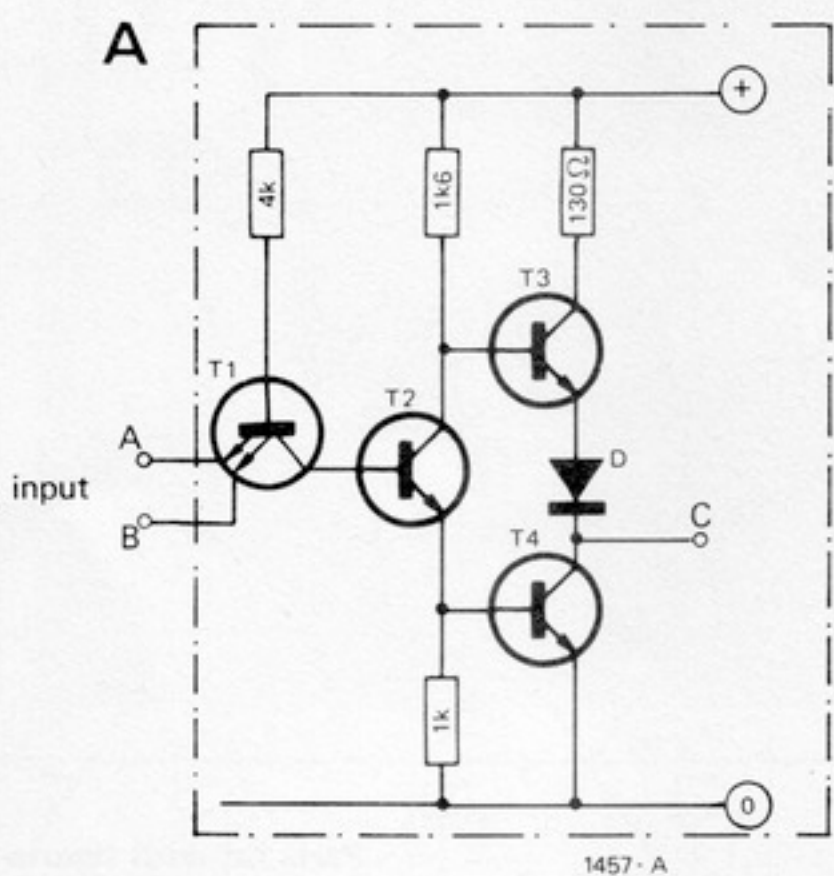

of T_3 and the drop in the 130Ω collector resistance. This output level therefore depends on the load current.

If the output of the NAND gate is LOW (logic '0'), the load current is fed to the supply zero via T_4 . The maximum load current ('sink current') is then determined by the maximum permissible current through T_4 , which is 30 mA for a 7400 IC.

touched, T_6 remains off and the NAND gate sees this as a '1' level.

The circuit diagram of the TAP

Figure 8 gives the circuit diagram of the TAP. It is designed around two ICs. The four NAND gates of IC_1 are used to form two RS-flipflops. The first one consists of the gates N_1/N_2 , and the second one of N_3/N_4 . A third is formed by the gates N_5/N_6 in IC_2 . The two remaining gates (N_7/N_8) of IC_2 form the one-shot, which provides the reset pulse. Its pulse width is determined by resistor R_8 and capacitor C_2 . Figure 9 shows an oscillogram of a reset pulse at the output of the one-shot (pin 8 of gate N_7). The pulse width is approximately 400 ns!

As appears from figure 9, the reset pulse is a '0'. The reset pulses are fed directly to the R-input of the three flipflops without diode coupling. This is possible because the emitters of the NAND gates are 'open'.

The set control for each flipflop takes place via the darlington circuit consisting of two transistors described earlier. For flipflop N_1/N_2 these are the transistors T_1 and T_2 . The collector of T_1 is connected direct to the set input of the flipflop. The negative-going pulse on this collector, when point A is touched, is used for driving the one-shot. To achieve a good switching edge, the collector of T_1 is connected to '1' level via resistor R_1 (in the quiescent state). As soon as A is

touched, the collector of T_1 switches from '1' to '0' and back again 50 times per second. Via diode D_1 this signal arrives on resistor R_9 . Consequently, transistor T_8 becomes conductive, and the drive input of the one-shot (pin 13 of gate N_8) is drawn to supply zero, so that the one-shot produces reset pulses 50 times per second.

Resistor R_4 in the base of T_2 prevents this transistor being damaged by static charges on the skin.

To avoid instability of the TAP, a capacitor C_3 is connected across the supply. Capacitor C_1 is provided for automatic reset when the supply is turned on. This is achieved by feeding the positive voltage surge, occurring during switch on, to the base of T_7 via R_7 . Consequently transistor T_7 and T_8 become momentarily conductive, and the one-shot produces a reset pulse.

As well as having a Q and \bar{Q} output, each flipflop also has extra S and \bar{S} outputs. These are intended as active attenuators. In the reset condition an S-output can be regarded as a relatively high-ohmic resistance relative to supply zero. Inversely, the \bar{S} -output is relatively low-ohmic. If, via a series resistor, a digital signal is fed to an S or an \bar{S} output, this S or \bar{S} output will function as a logic-controlled attenuator.

The switching speed of the various outputs is so high that nothing of the TTL character is lost. Figure 10 shows an oscillogram of a switching edge of one of the binary outputs of the TAP. As is seen from this figure, the rise time is less than 10 ns.

The circuit shown in figure 8 can be considered a universal TAP. The points RB (Reset-Bar) and CB (Contact-Bar) provide an extra output for using several TAPs in conjunction with each other.

Table 1 gives the truth table of the TAP, and table 2 gives various specifications.

The printed circuit board

Figure 12 shows the circuit board of the TAP. All the inputs are along the upper edge of the board, and the outputs along the lower edge. The supply terminals and the RB-CB rails are on one side.

Screened cable should be used for the input connections.

TAP applications

A simple TAP application, an on/off switch for a 220 V lamp, is shown in figure 13.

In figure 14 a similar circuit for operating three lamps is shown.

If the diodes D_1 , D_2 and D_3 are omitted from the TAP in figure 14, the result is a triple lamp switch with one common reset. In cases where a triple touch control switch with a common reset is insufficient, more TAPs can be used in conjunction. The RB- and CB-rails of all TAPs used must then be interconnected. Figure 15 gives a simple example. Of course, only one TAP need be provided with a one-shot reset circuit.

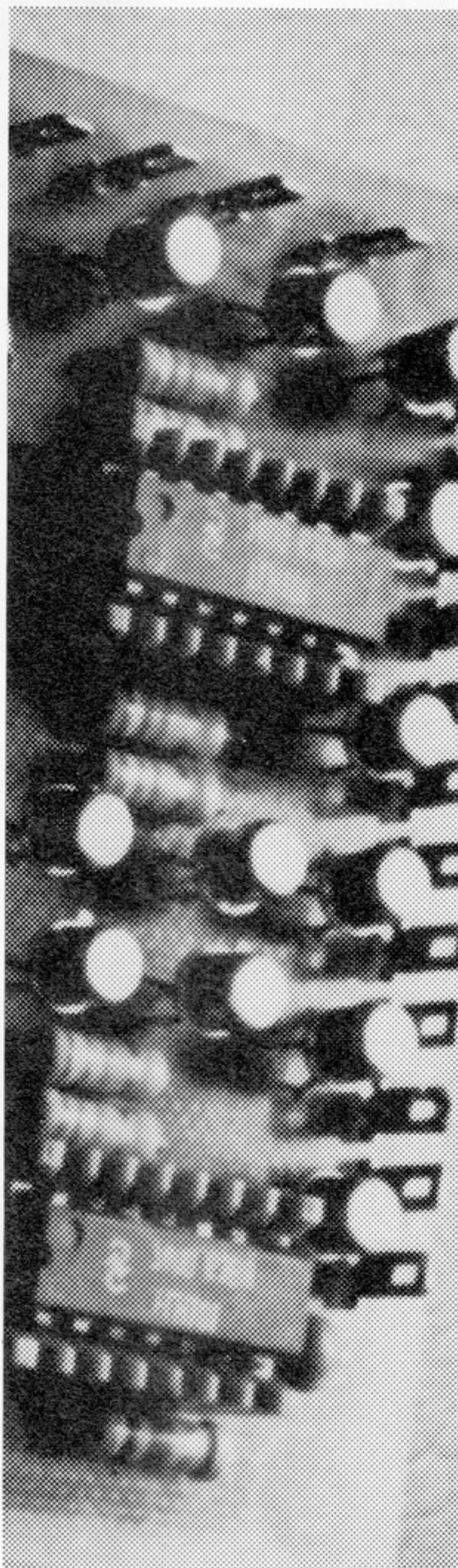

Table 1. Truth table of the TAP

		Q_1	\bar{Q}_1	Q_2	\bar{Q}_2	Q_3	\bar{Q}_3
after switch-on		1	0	1	0	1	0
touch point	A	0	1	1	0	1	0
	B	1	0	0	1	1	0
	C	1	0	1	0	0	1
reset		1	0	1	0	1	0

positive logic '1' = +5 V

Figure 7. An RS-flipflop built from two NAND gates. The transistors T_5 and T_6 plus resistor R_1 form the 'set' circuit.

Figure 8. The complete circuit diagram of a TAP.

Figure 9. Photographed oscillogram of a one-shot reset pulse. The one-shot produces this pulse each time input A, B, C or the reset is touched. At a prolonged touch of any of the touch points, the one-shot produces 50 such pulses per second.

Figure 10. Photographed oscillogram of one of the binary outputs during switching.

Figure 11. Equivalent block diagram of the TAP circuit.

Parts list with figures 8 and 12.

Resistors:

R_1, R_2, R_3	= 100 k
R_4, R_5, R_6, R_7	= 10 M
R_8	= 1 k
$R_9, R_{10}, R_{11}, R_{12}$	= 27 k
R_{13}, R_{14}, R_{15}	= 27 k

Capacitors:

C_1	= 270 p
C_2	= 270 p
C_3	= 47 n

Semiconductors:

D_1, D_2, D_3	= DUG
$T_1, T_2, T_3, T_4, T_5, T_6, T_7$	= BC 107 or BC 108, BC 109
T_8	= AC 126 or equiv.
$T_9, T_{10}, T_{11}, T_{12}$	= TUN
T_{13}, T_{14}	= TUN
IC-1, IC-2	= 7400 (DIL)

7

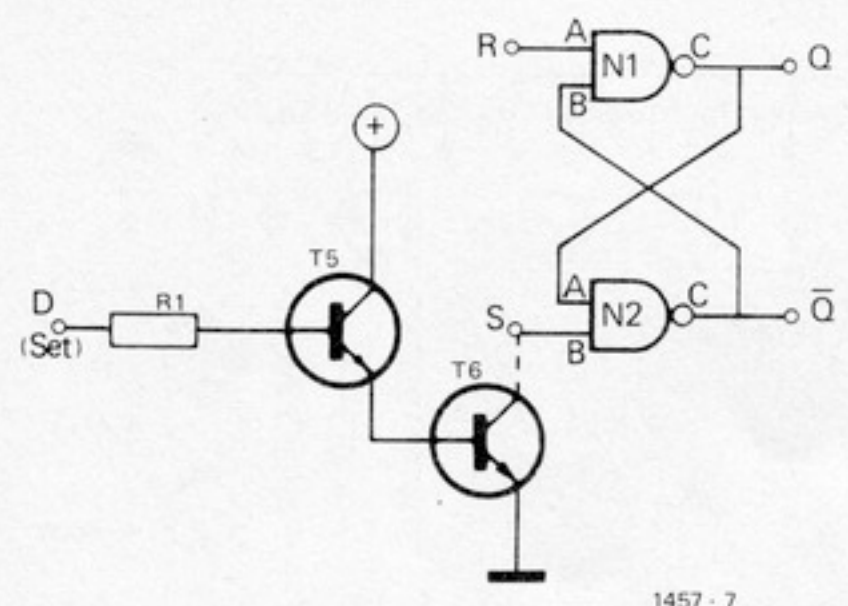

9

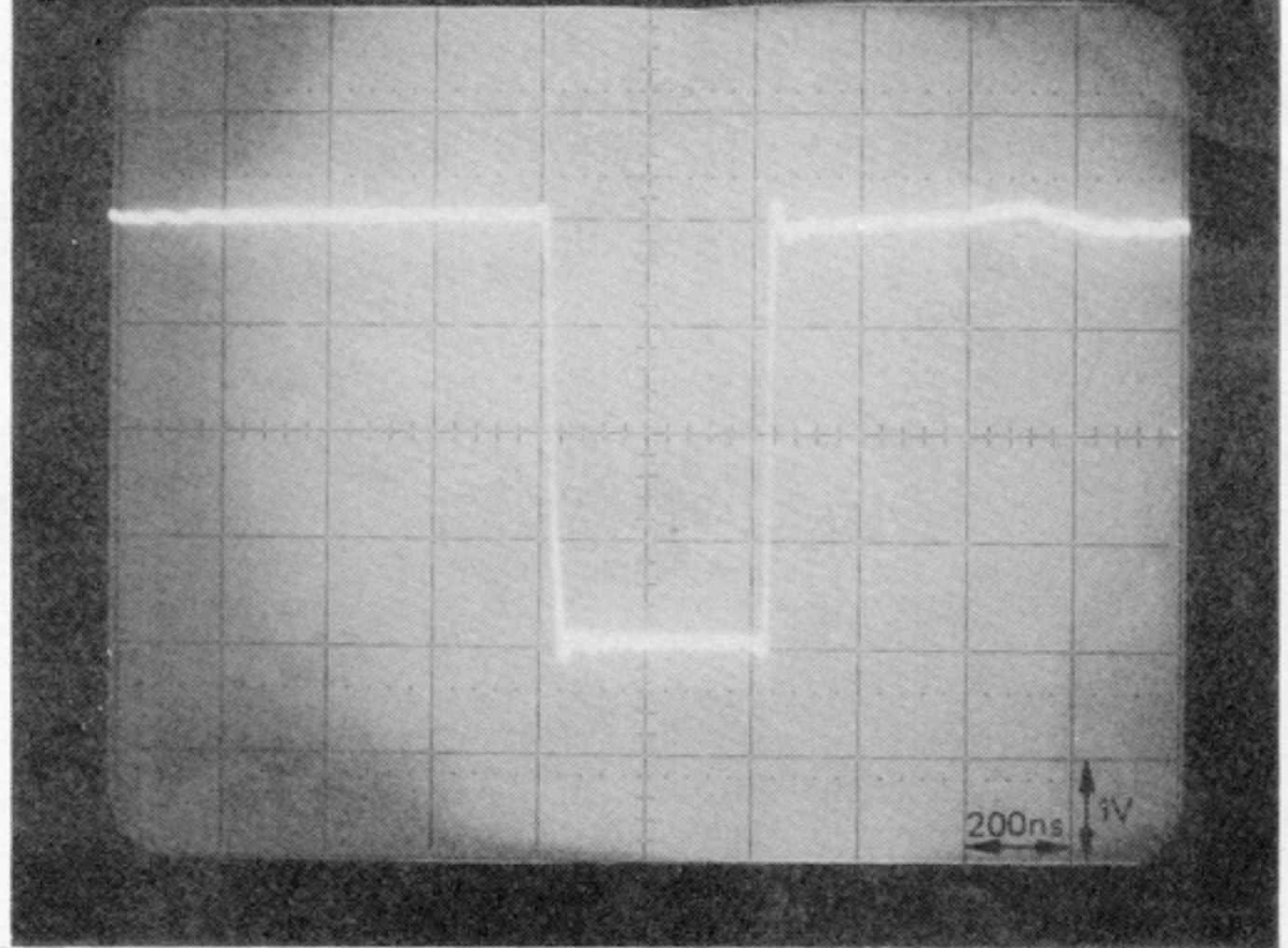

11

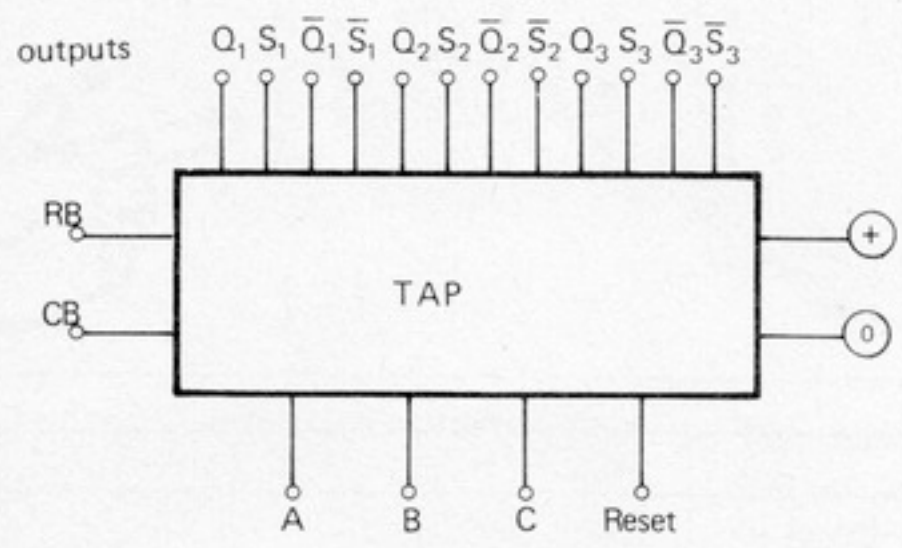

10

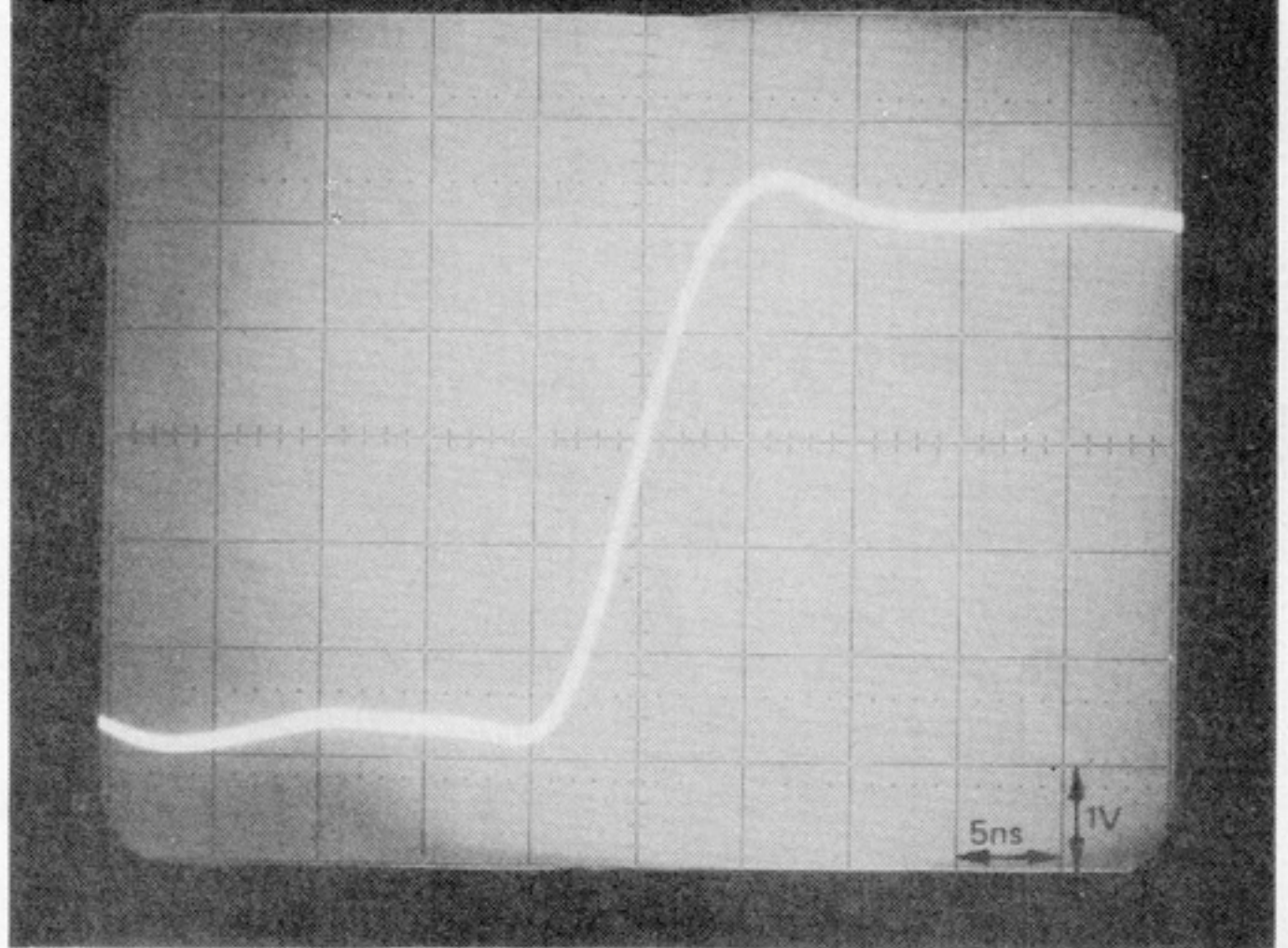

Table 2 TAP specifications

supply voltage	: +4.5 V ... +6.4 V
input impedance (each input)	: > 10 M
response voltage (each input)	: < 1 V (RMS)
response current (each input)	: < 160 nA
maximum response delay	: 20 ms (50 Hz mains)
switching time (each output)	: < 1 μs
output voltage logic '1' (each Q and Q̄)	: > 4.5 V p.p. (V _b = 6 V)
output voltage logic '0' (each Q and Q̄)	: < 150 mV p.p. (V _b = 6 V)
output current logic '1' (each Q and Q̄)	: 0.4 mA
sink current logic '0' (each Q and Q̄)	: -16 mA
required continuous current under no-load conditions	: 16 mA (V _b = 5 V) : 20 mA (V _b = 6 V)

8

